

ATK 100 FLH R

Technische Informationen

ATK 100 FLH R
Technical Information



Konstruktionsbeispiel

Construction example

Ebene Fassadentafeln, sichtbar befestigt

Plane facade panels, visible fixing



Konstruktionsbeispiel

Construction example

Horizontale Metall-Trapezprofile, sichtbar befestigt

Horizontal trapezoidal profiles, visible fixing

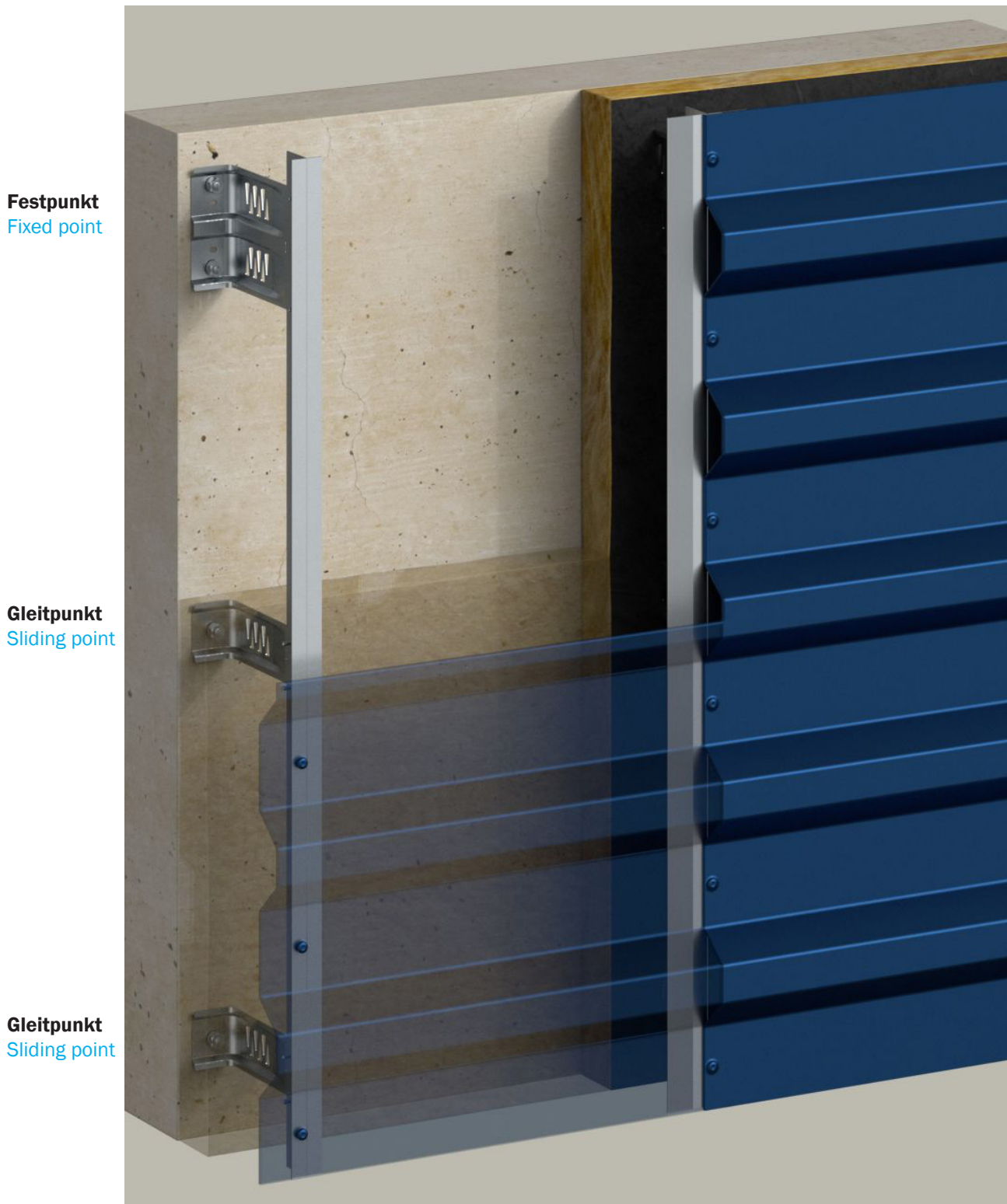

Konstruktionsbeispiel

Construction example

Ebene Platten/Keramik, Klammerbefestigung
Plane panels/ceramic tiles, clamp fixing



Konstruktionsbeispiel

Construction example

Ziegelfassade, Klammerbefestigung

Terracotta, clamp fixing

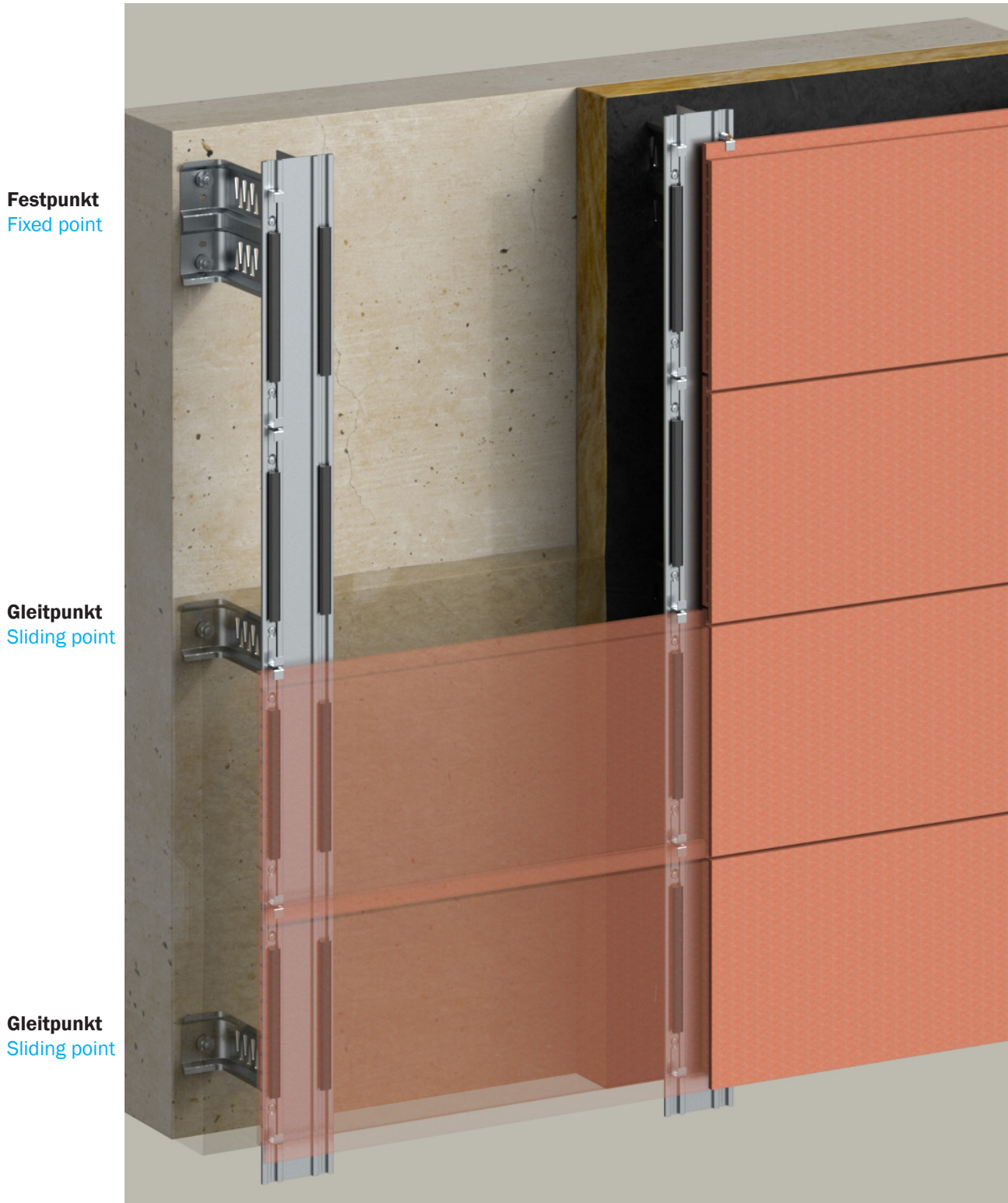

Wandabstände

Distance from the wall

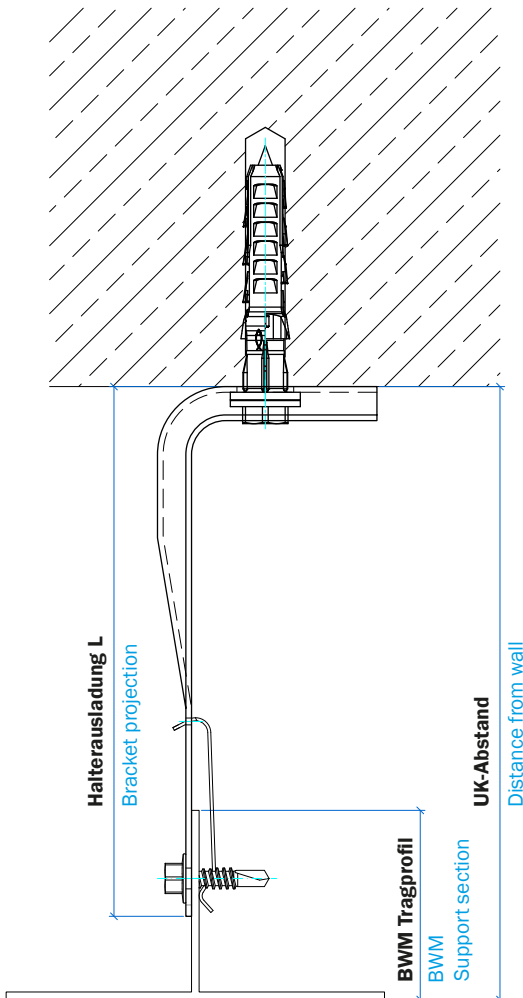

| Halterausladung L (mm) Bracket projection L (mm) | UK-Abstand (mm) Distance from the wall (mm) |
|---|--|
| 120 | 122 bis / up to 152 |
| 140 | 142 bis / up to 172 |
| 160 | 162 bis / up to 192 |
| 180 | 182 bis / up to 212 |
| 200 | 202 bis / up to 232 |
| 220 | 222 bis / up to 252 |
| 240 | 242 bis / up to 272 |
| 260 | 262 bis / up to 292 |
| 280 | 282 bis / up to 312 |
| 300 | 302 bis / up to 332 |
| 320 | 322 bis / up to 352 |
| 340 | 342 bis / up to 372 |

Schnittübersicht

Section overview

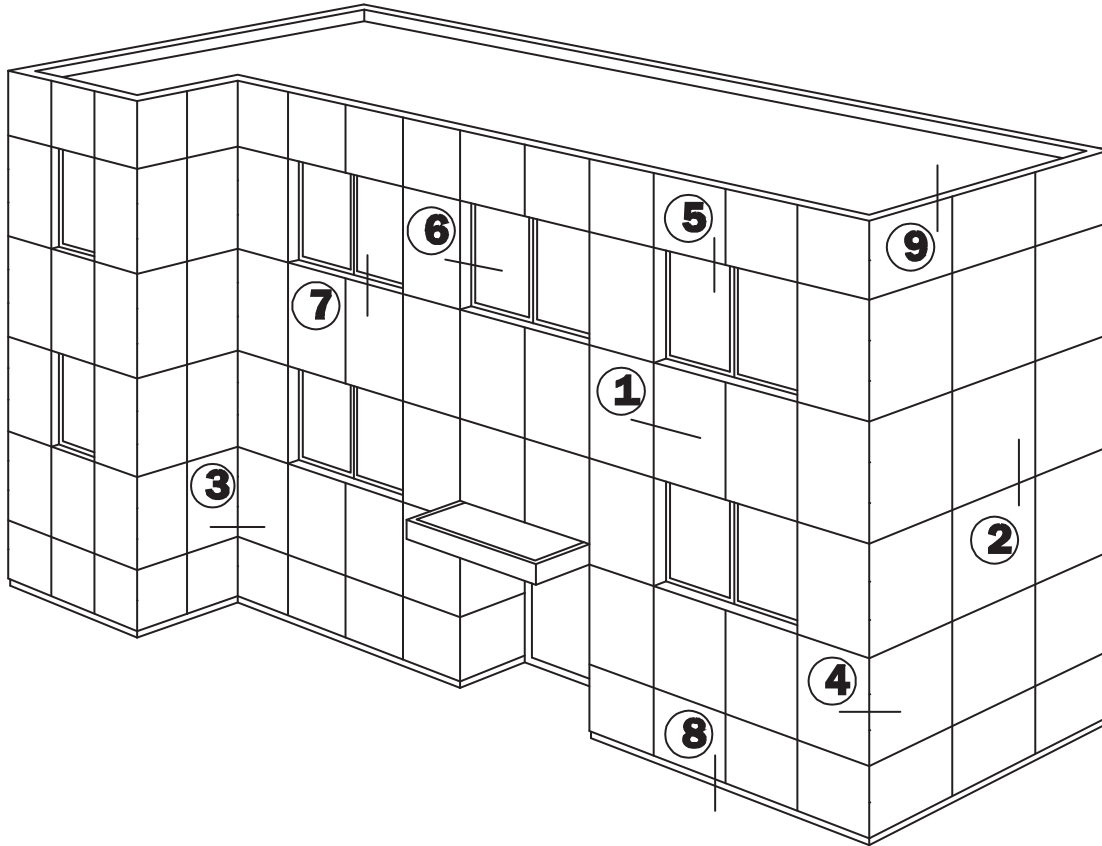

Schnitt 1
Section 1

Horizontalschnitt
Horizontal section

Schnitt 6
Section 6

Fensterleibung
Window embrasure

Schnitt 2
Section 2

Vertikalschnitt
Vertical section

Schnitt 7
Section 7

Fensterbank
Window sill

Schnitt 3
Section 3

Innenecke
Internal corner

Schnitt 8
Section 8

Sockelabschluss
Lower edge (bottom end)

Schnitt 4
Section 4

Außenecke
External corner

Schnitt 9
Section 9

Attikaabschluss
Attic connection (top end)

Schnitt 5
Section 5

Jalousiekasten
Roller-blind box

Schnitte

Sections

Schnitt 1 Horizontalschnitt

Section 1 Horizontal section

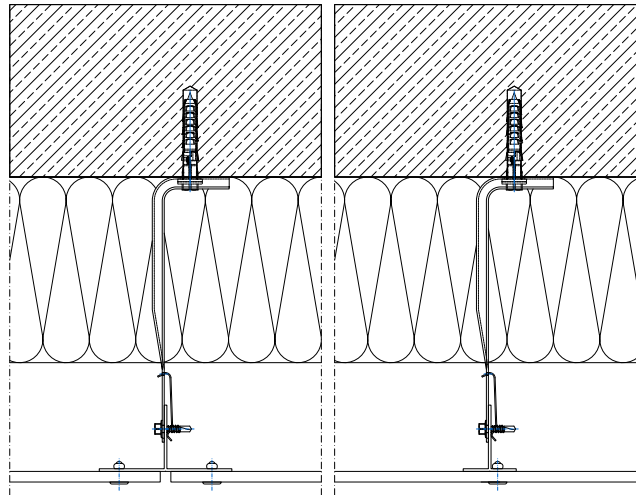

Schnitt 2a Vertikalschnitt

Section 2a Vertical section

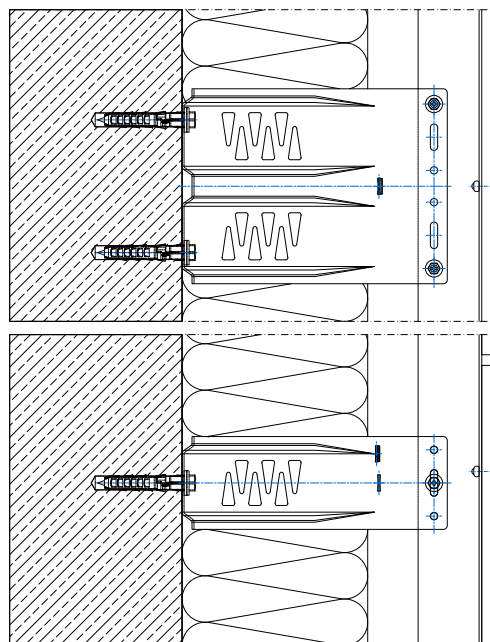

Angrenzende Bauteile sind hier nur schematisch dargestellt. Die konkrete Detailausbildung ist unter Beachtung von Normen, Vorschriften und Richtlinien objektbezogen separat zu planen.

Adjacent components are shown here only schematically. The concrete details are to be planned separately in respect of the particular building involved. This must be done in accordance with the relevant standards, regulations and guidelines.

Schnitte

Sections

Schnitt 2b Vertikalschnitt

Section 2b Vertical section

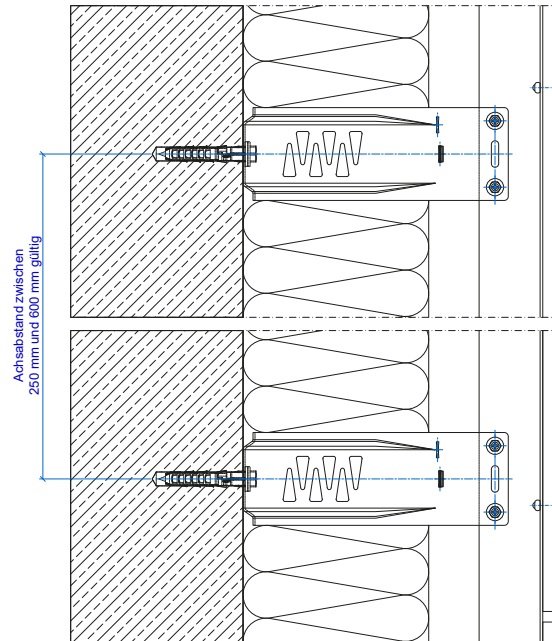

Schnitt 3 Innenecke

Section 3 Internal corner

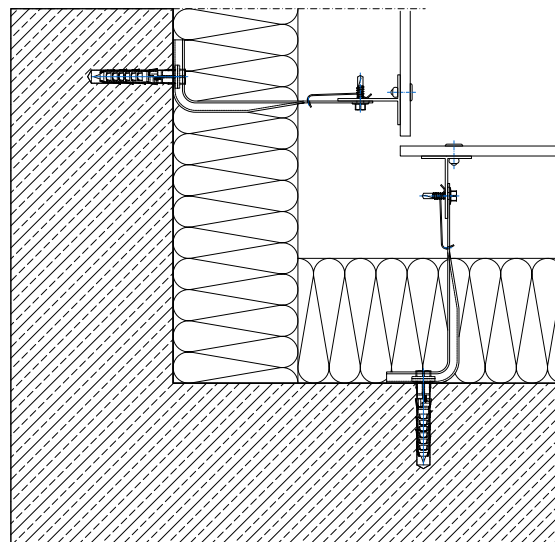

Angrenzende Bauteile sind hier nur schematisch dargestellt. Die konkrete Detailausbildung ist unter Beachtung von Normen, Vorschriften und Richtlinien objektbezogen separat zu planen.

Adjacent components are shown here only schematically. The concrete details are to be planned separately in respect of the particular building involved. This must be done in accordance with the relevant standards, regulations and guidelines.

Schnitte

Sections

Schnitt 4 Außenecke

Section 4 External corner

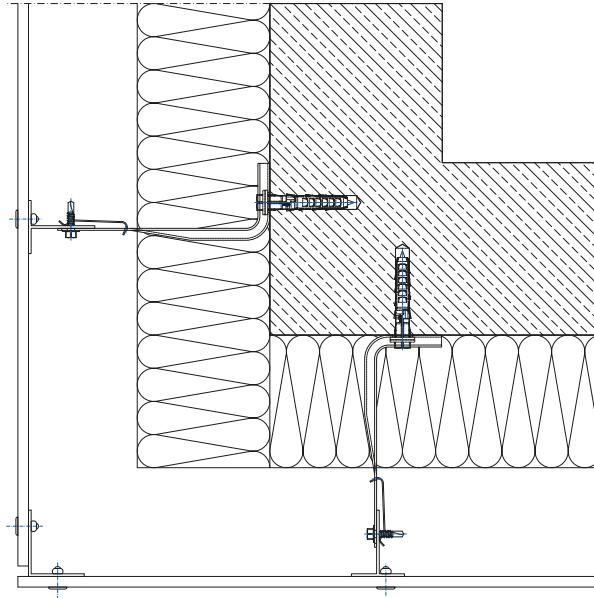

Schnitt 5 Jalousiekasten

Section 5 Roller-blind box

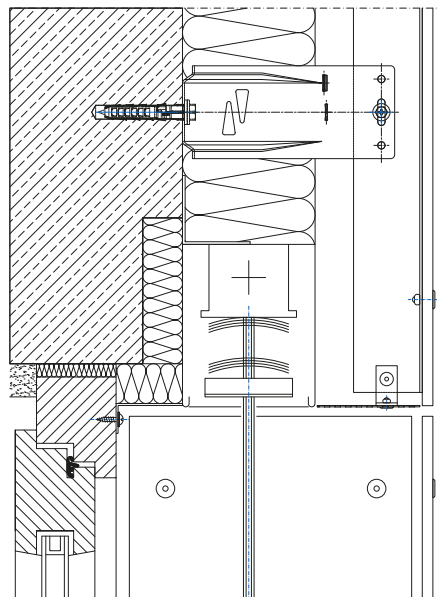

Angrenzende Bauteile sind hier nur schematisch dargestellt. Die konkrete Detailausbildung ist unter Beachtung von Normen, Vorschriften und Richtlinien objektbezogen separat zu planen.

Adjacent components are shown here only schematically. The concrete details are to be planned separately in respect of the particular building involved. This must be done in accordance with the relevant standards, regulations and guidelines.

Schnitte

Sections

Schnitt 6 Fensterleibung

Section 6 Window embrasure

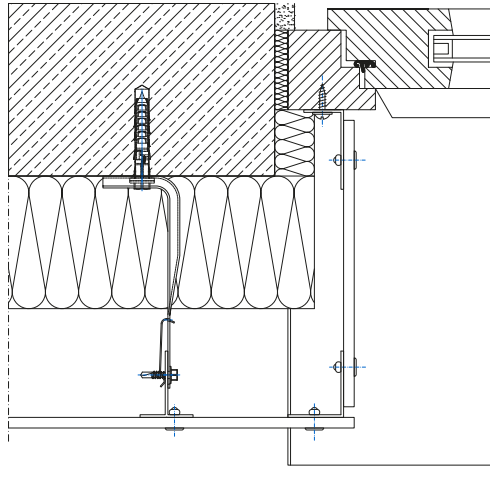

Schnitt 7 Fensterbank

Section 7 Window sill

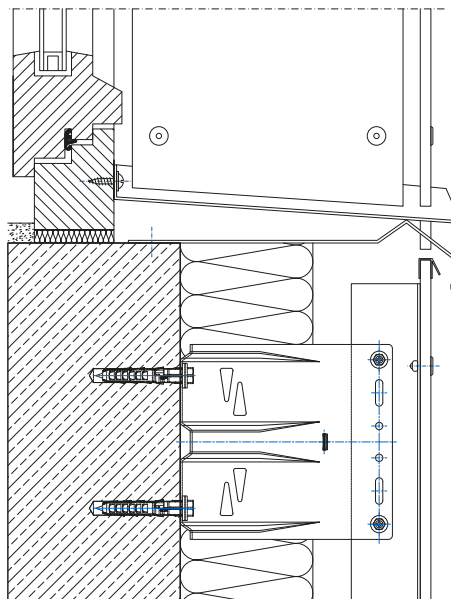

Angrenzende Bauteile sind hier nur schematisch dargestellt. Die konkrete Detailausbildung ist unter Beachtung von Normen, Vorschriften und Richtlinien objektbezogen separat zu planen.

Adjacent components are shown here only schematically. The concrete details are to be planned separately in respect of the particular building involved. This must be done in accordance with the relevant standards, regulations and guidelines.

Schnitte

Sections

Schnitt 8 Sockelabschluss

Section 8 Lower edge

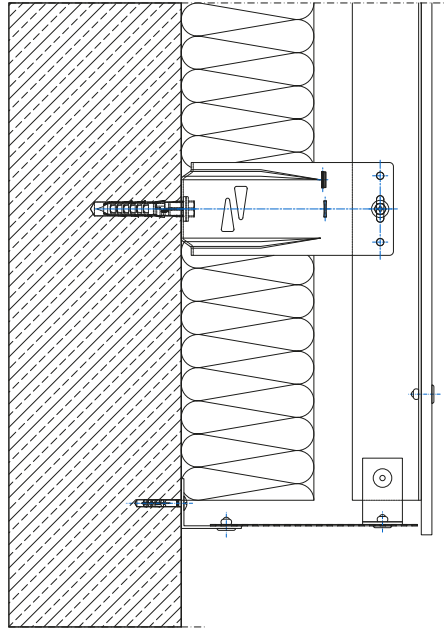

Schnitt 9 Attikaabschluss

Section 9 Attic connection

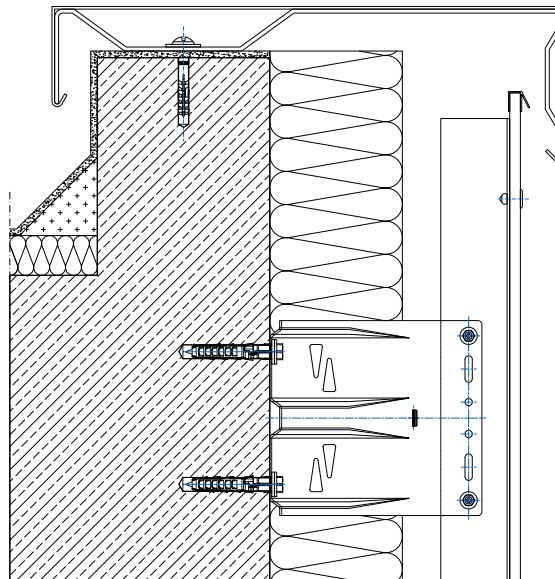

Angrenzende Bauteile sind hier nur schematisch dargestellt. Die konkrete Detailausbildung ist unter Beachtung von Normen, Vorschriften und Richtlinien objektbezogen separat zu planen.

Adjacent components are shown here only schematically. The concrete details are to be planned separately in respect of the particular building involved. This must be done in accordance with the relevant standards, regulations and guidelines.

Montagefolge

Mounting sequence

1

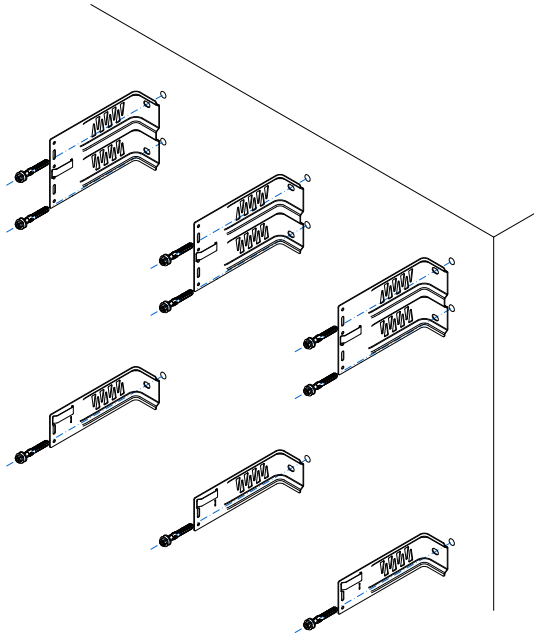

2

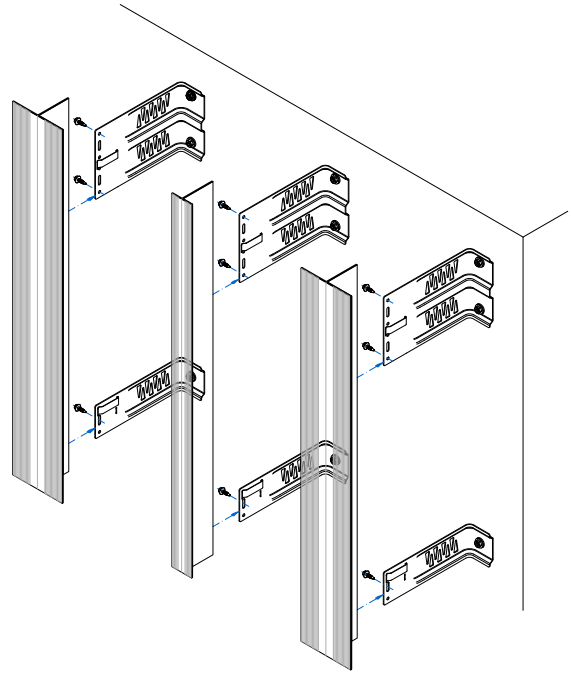

3

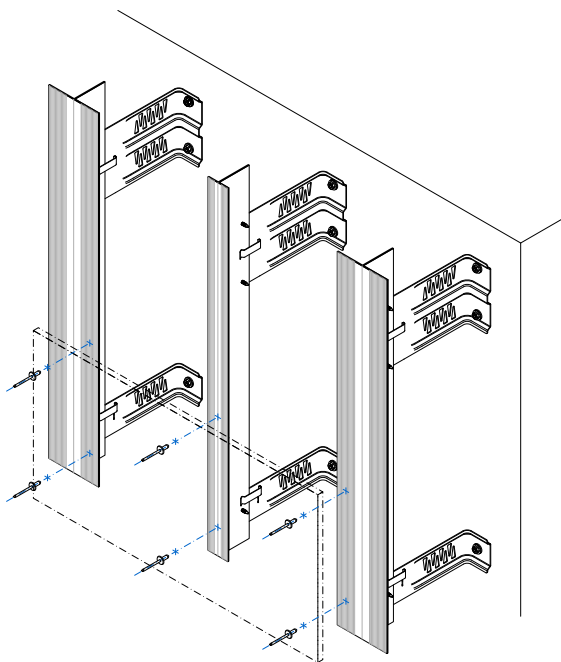

4

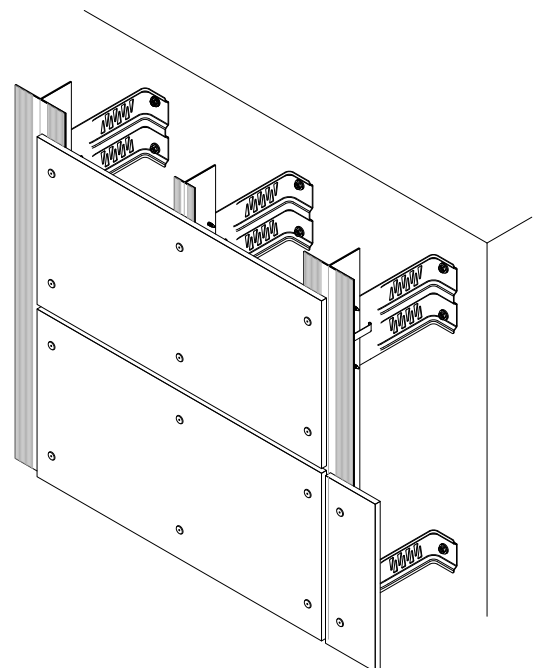

Montage der BWM-Haltefeder

Mounting of the BWM-Inox-spline

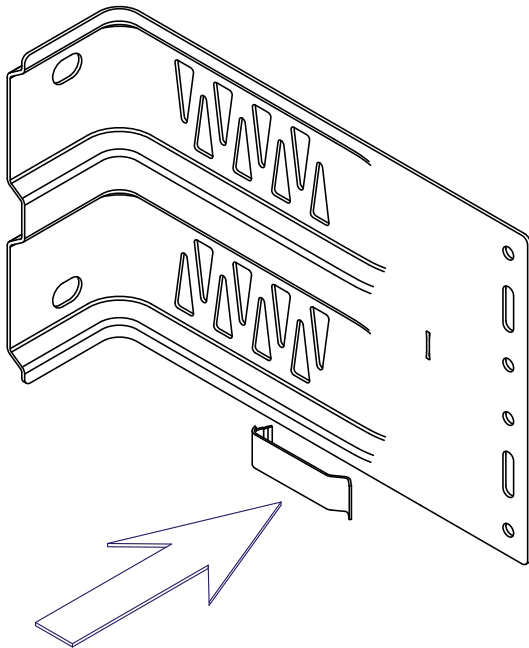

Einstecken
Insert

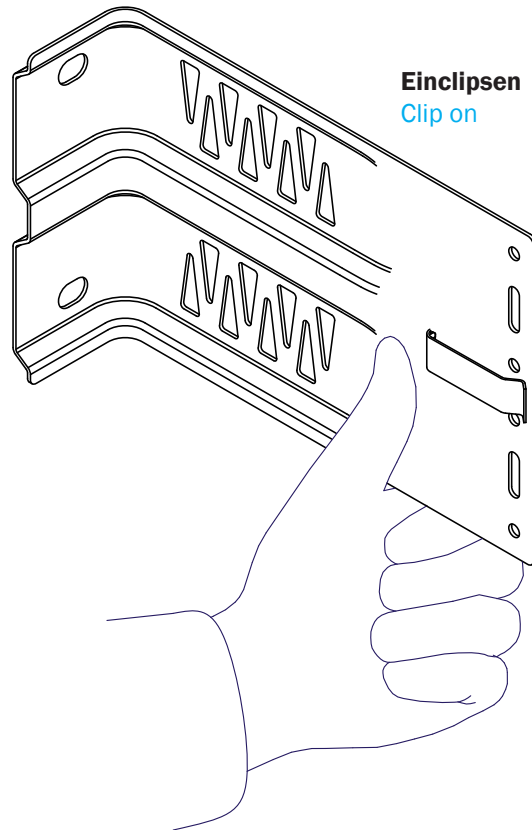

Einclippen
Clip on

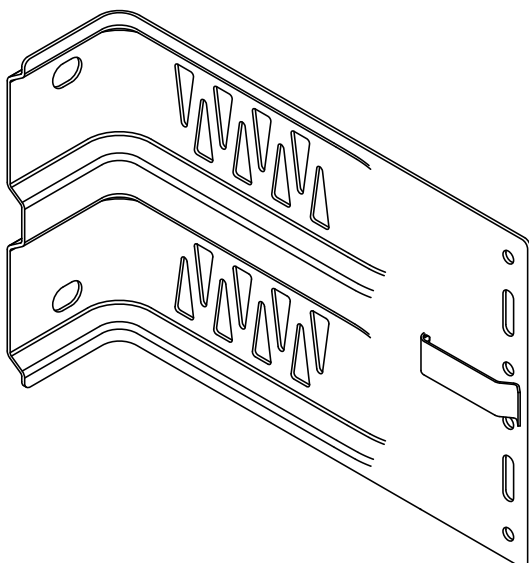

Fertig
Finished

Tragprofile

Support sections

T120/52/2
Art.-Nr. 632730

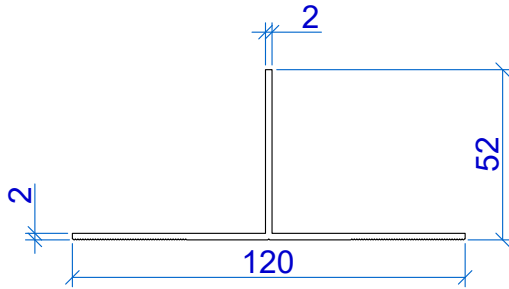

T110/52/2
Art.-Nr. 632713

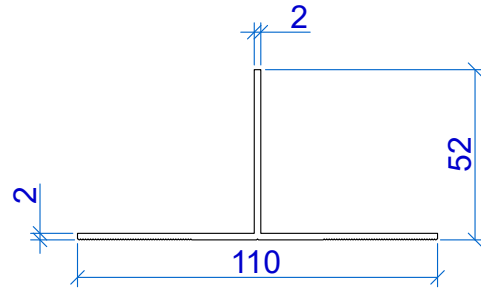

T100/52/2
Art.-Nr. 632700

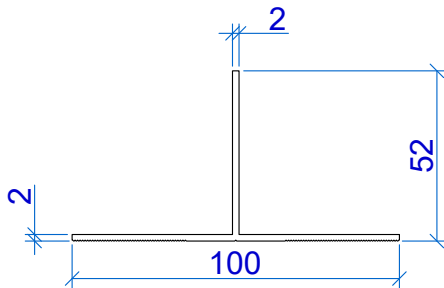

T70/52/2
Art.-Nr. 632770

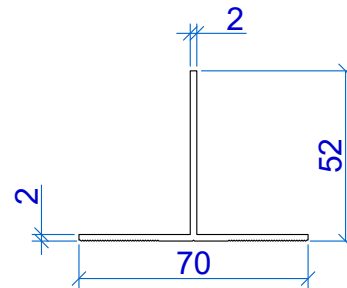

T40/52/2
Art.-Nr. 632740

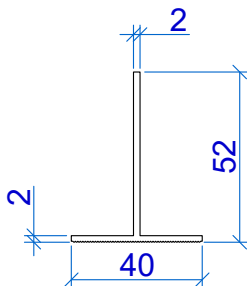

L42/52/2
Art.-Nr. 632720

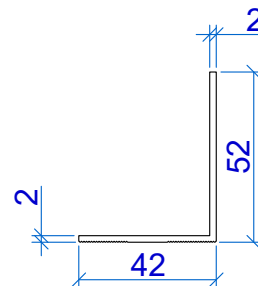

Tragprofile

Support sections

T160/52/2
Art.-Nr. 632760

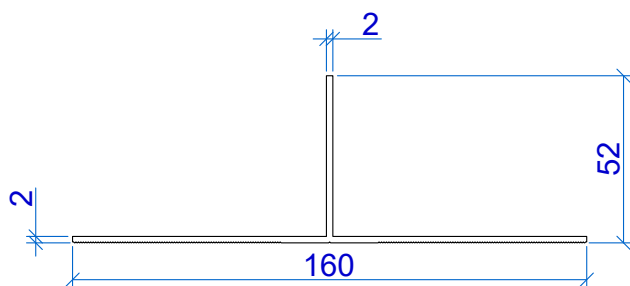

T150/52/2
Art.-Nr. 632750

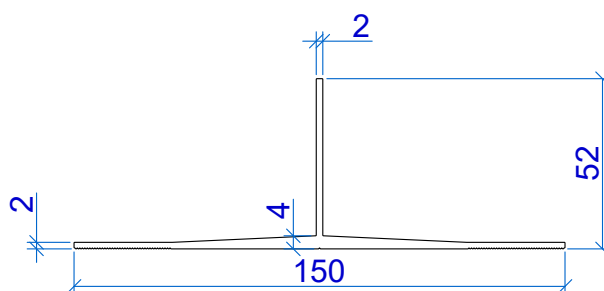

Tulpenprofil
Art.-Nr. 611267

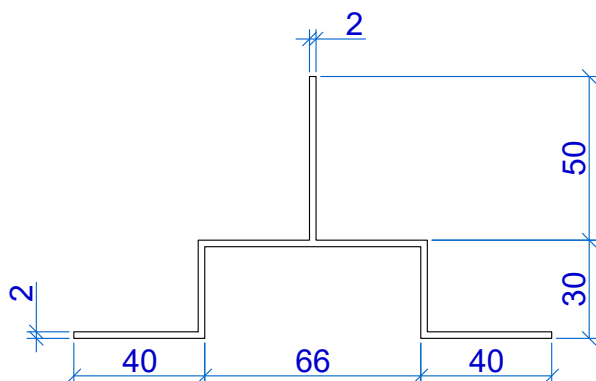

Tragprofile

Support sections

T120/50/2 (glatt / fair-faced)
 Art.-Nr. 662730

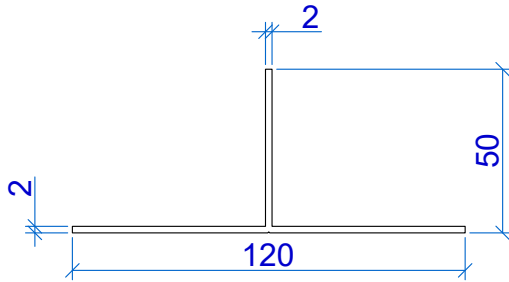

T100/50/2 (glatt / fair-faced)
 Art.-Nr. 662700

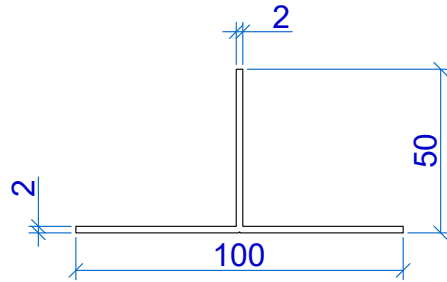

T80/52/2 (glatt / fair-faced)
 Art.-Nr. 632780

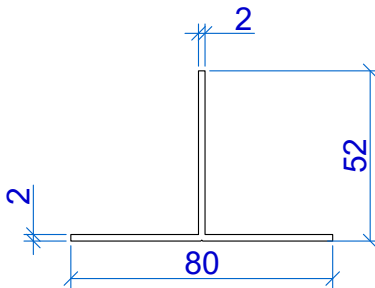

T60/52/2 (glatt / fair-faced)
 Art.-Nr. 632710

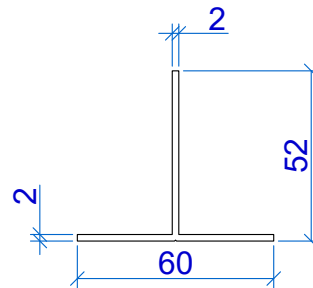

T40/50/2 (glatt / fair-faced)
 Art.-Nr. 662740

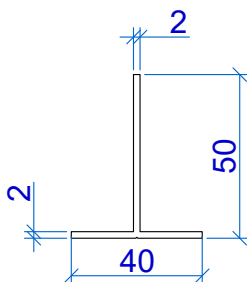

L40/50/2 (glatt / fair-faced)
 Art.-Nr. 662720

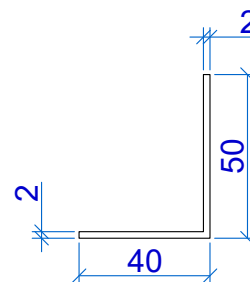

Tragprofile

Support sections

T120/52/2,5 (glatt / fair-faced)
Art.-Nr. 632735

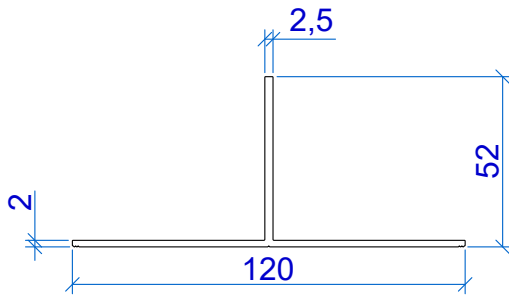

T40/52/2,5 (glatt / fair-faced)
Art.-Nr. 632745

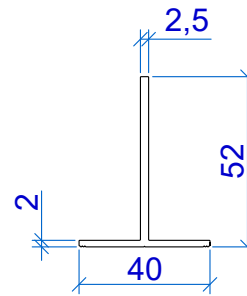

T120/32/2-3 (glatt / fair-faced)
Art.-Nr. 632734

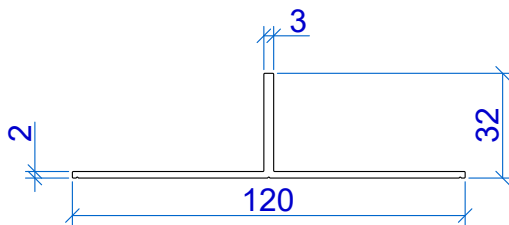

T50/32/2-3 (glatt / fair-faced)
Art.-Nr. 632751

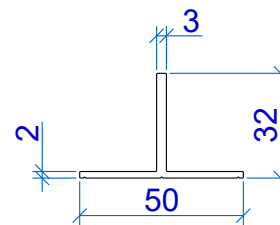

Tragprofile - Schwarz eloxiert

Support sections - Black anodized

T120/52/2
Art.-Nr. S632731

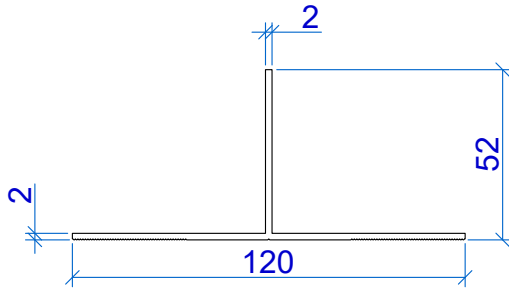

T110/52/2
Art.-Nr. S632713

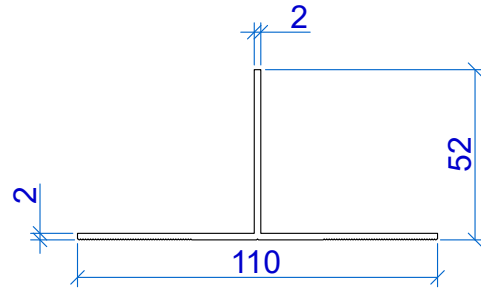

T100/52/2
Art.-Nr. S63737

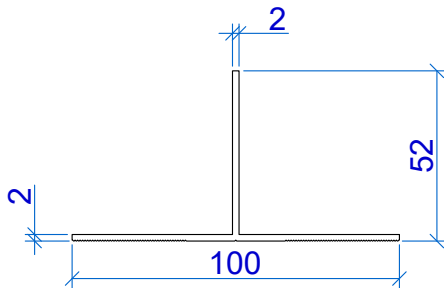

T40/52/2
Art.-Nr. S632739

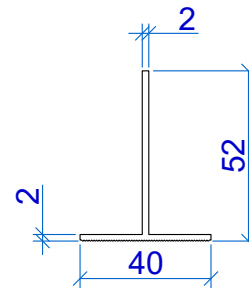

L42/52/2
Art.-Nr. S632721

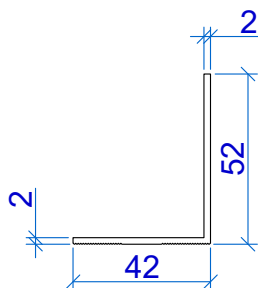

Tragprofile - Schwarz eloxiert

Support sections - Black anodized

T100/50/2 (glatt / fair-faced)
Art.-Nr. S662700

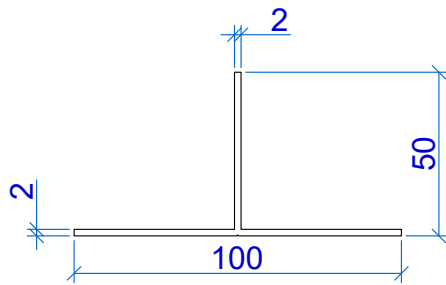

T60/52/2 (glatt / fair-faced)
Art.-Nr. S632711

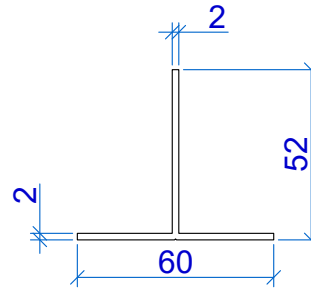

T120/52/2,5 (glatt / fair-faced)
S632735

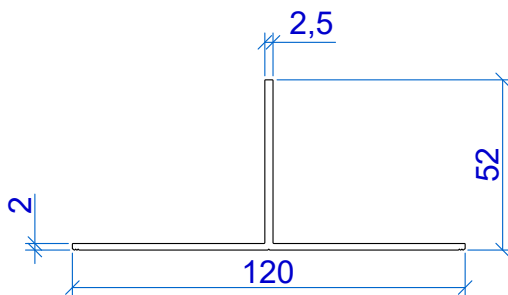

T40/52/2,5 (glatt / fair-faced)
S632745

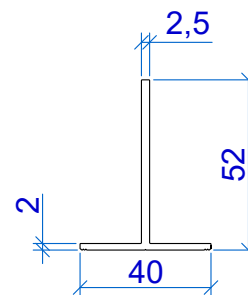

Weitere Profile auf Anfrage
Further support section on demand

Clip 107

Clip 107

Material: EN AW 6063 T 66 / TPE TR 91
Zur Befestigung von 2 mm Kassetten und Paneelen
 For fixing of 2 mm coffers and panels

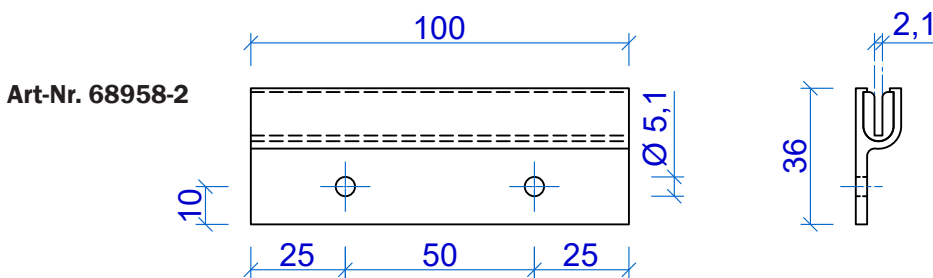
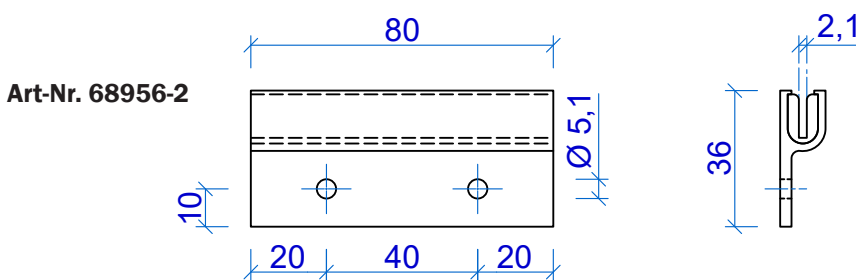
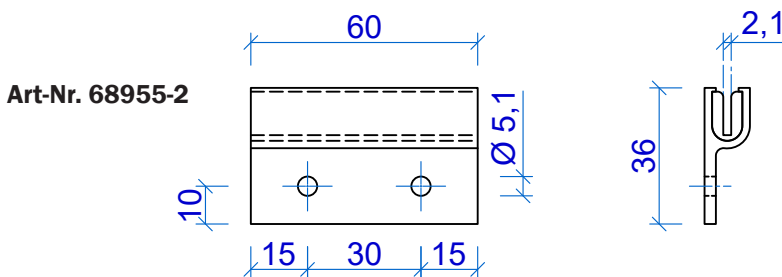
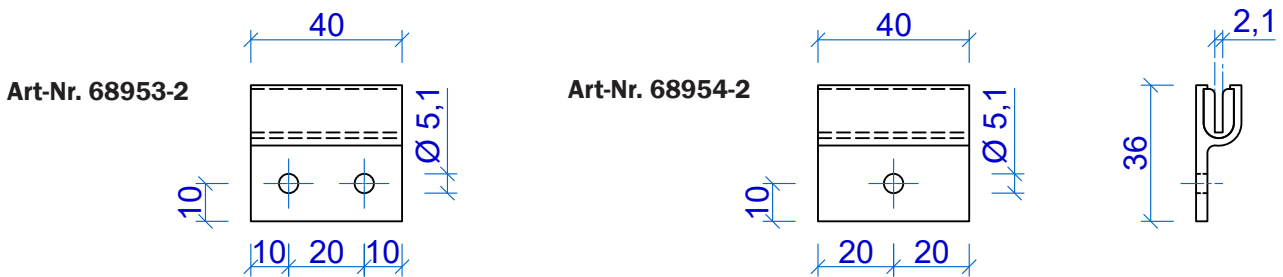
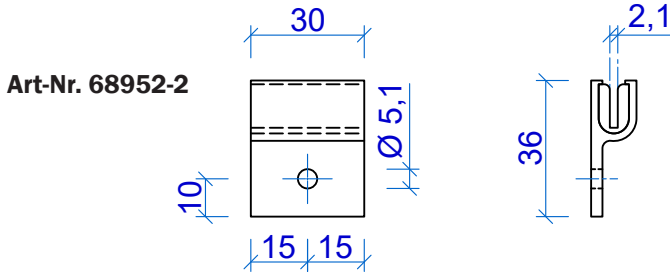

Andere Längen auf Anfrage
 Further dimensions on demand

Clip 107

Clip 107

Material: EN AW 6063 T 66 / TPE TR 91

Zur Befestigung von 3 mm Kassetten und Paneelen

For fixing of 3 mm coffers and panels

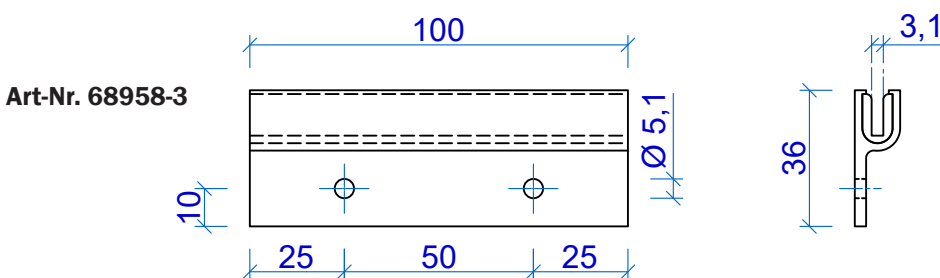
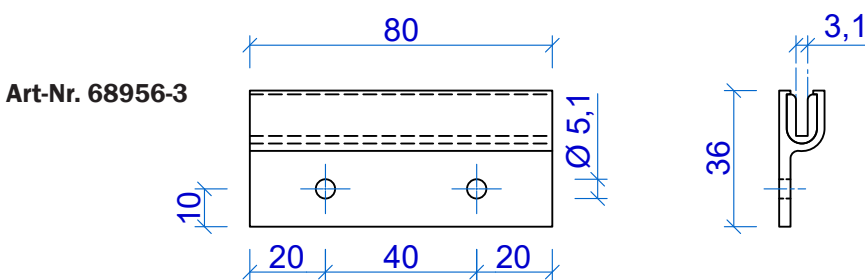
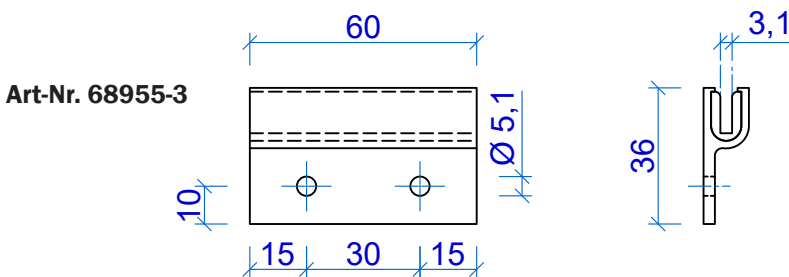
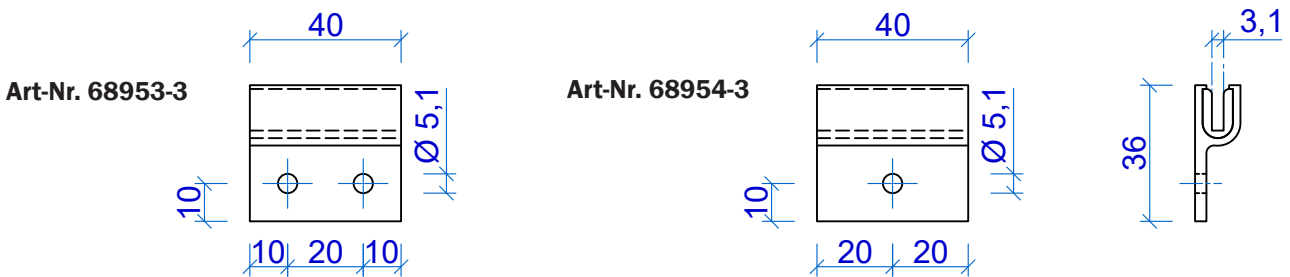
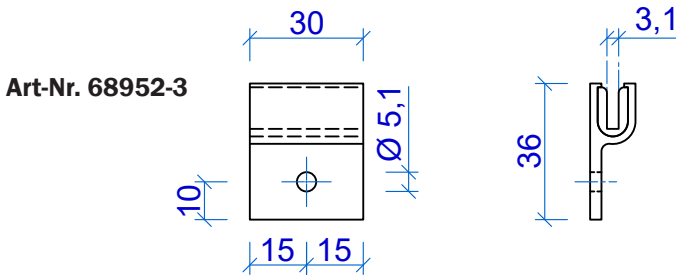

Andere Längen auf Anfrage
Further dimensions on demand

Clip 107

Clip 107

Material: EN AW 6063 T 66 / TPE TR 91
Zur Befestigung von 4 mm Kassetten und Paneelen
 For fixing of 4 mm coffers and panels

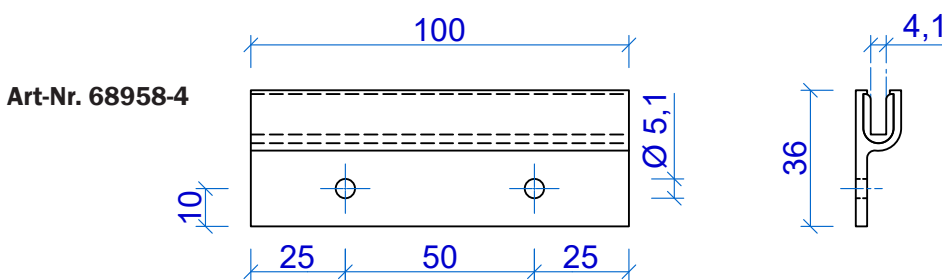
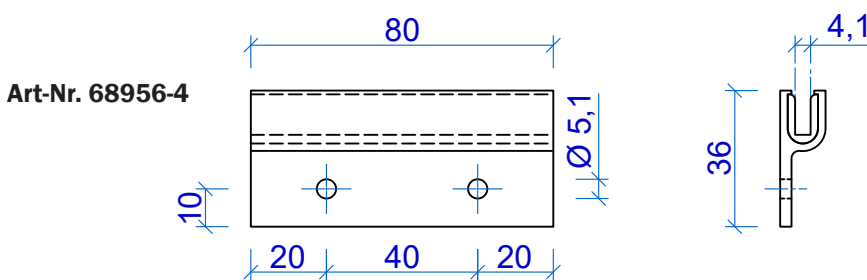
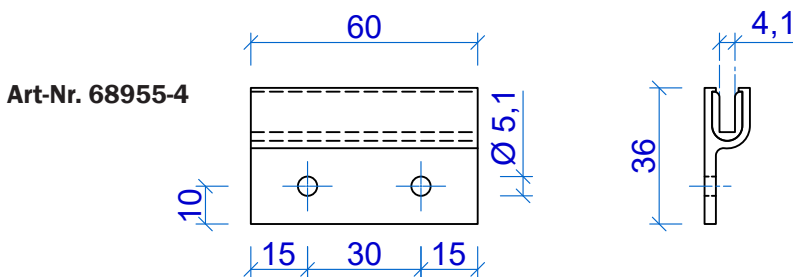
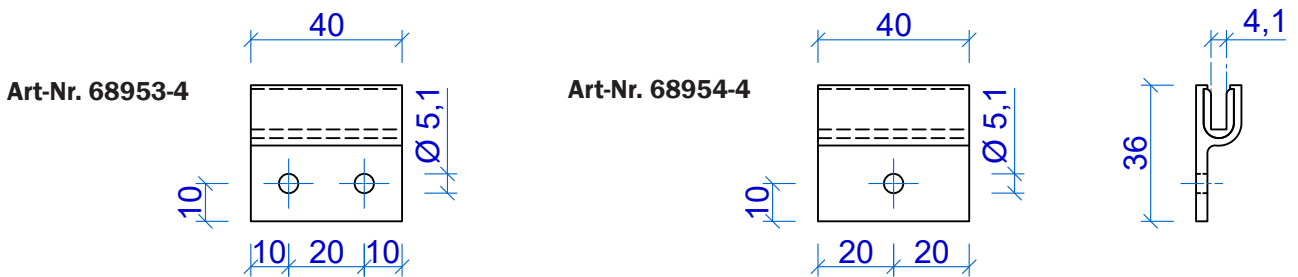
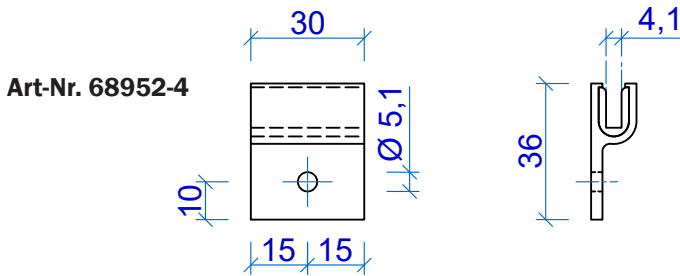

Andere Längen auf Anfrage
 Further dimensions on demand

Klammer ATK 100 KL für Plattendicken (PD) : 8/9,5/10,5/11,5/13 mm (Tol. +0,4/-1,0)

Clamps ATK 100 KL for tile thickness (PD) : 8/9,5/10,5/11,5/13 mm (Tol. +0,4/-1,0)

Anfangsklammer

Initial Clamp

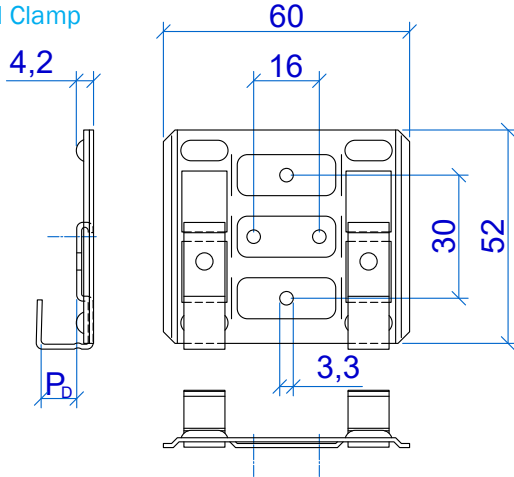

Fugenklammer

Grooved Clamp

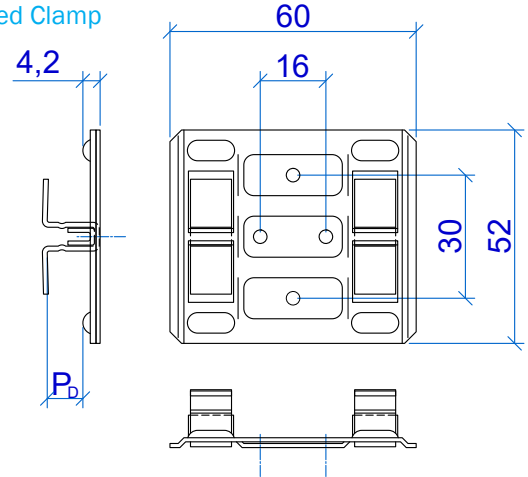

Anfangsklammer Leibung

Initial Clamp Embrasure

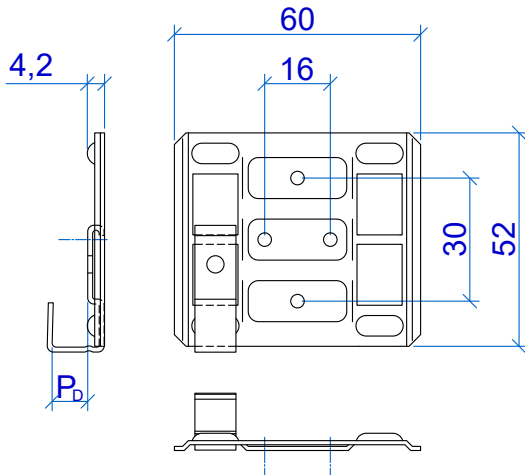

Fugenklammer Leibung

Grooved Clamp Embrasure

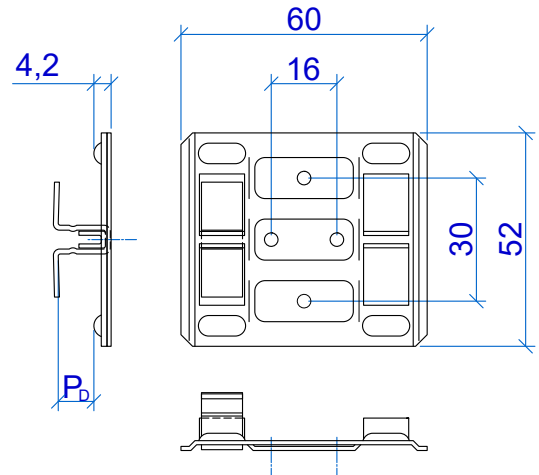

Drucklippe

EPDM gasket

Art. 1158

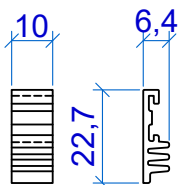

BWM-Spezialniet

3,2x8 Niro-Niro
mit langem Dorn

BWM-Special Rivet
3,2x8 stainless steel
with long spike

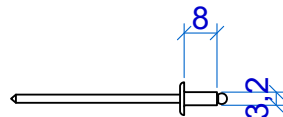

blank / blank
Art.-Nr. 32800

schwarz / black
Art.-Nr. 3280S

Wandwinkel - Edelstahl

L-Brackets - Stainless steel

H = 147 mm
 H = 147 mm

Verwendbar als Fest-, Gleit- oder Fest-/Gleitpunkt
 Suitable as fixed and/or sliding point

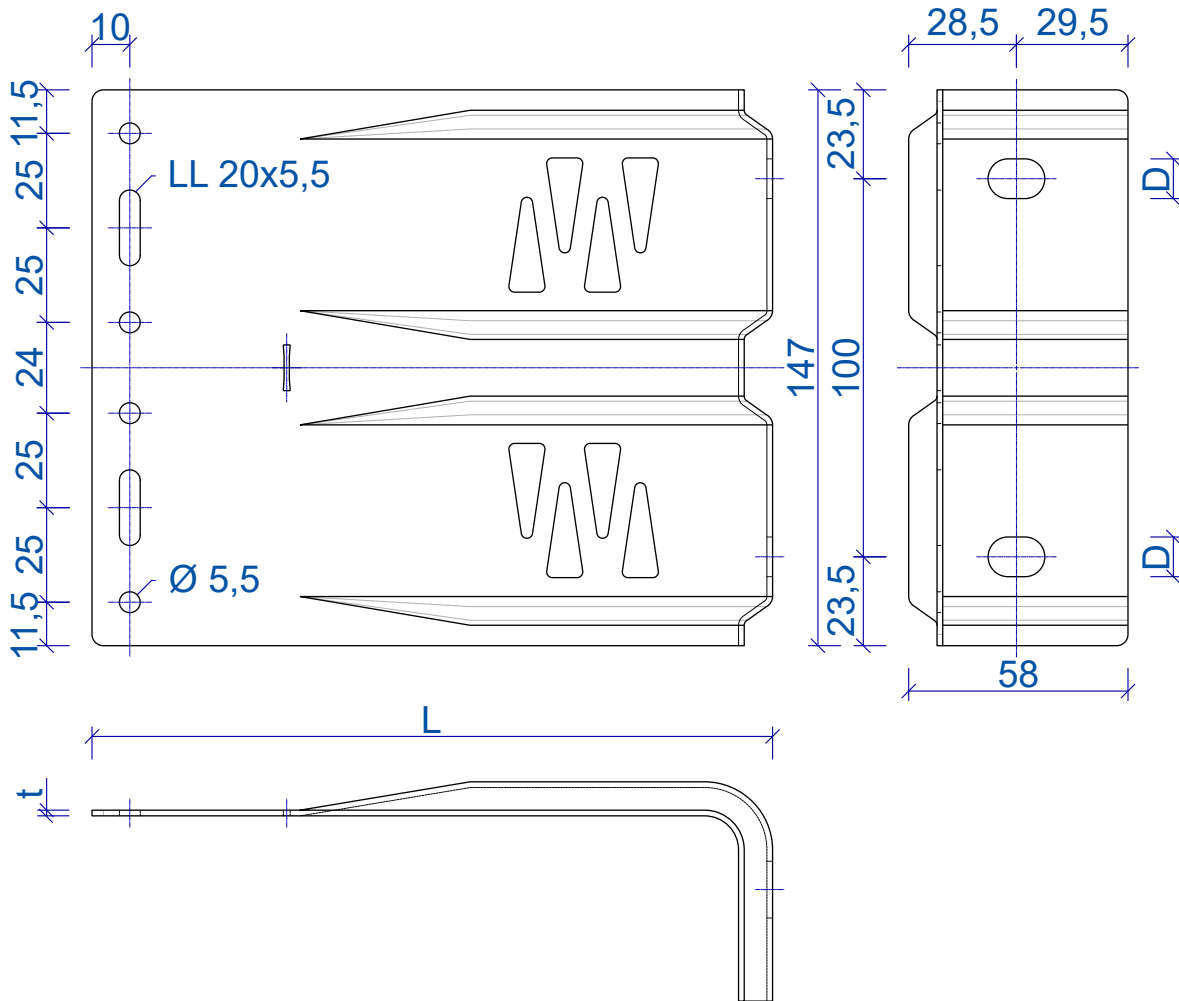

L = 120 / 140 / 160 / 180 / 200 / 220 / 240 / 260 / 280 / 300 / 320 / 340 mm
t = 1,5 mm
D = 10,5x15 mm

Wandwinkel - Edelstahl

L-Brackets - Stainless steel

H = 70 mm

Verwendbar als Fest- oder Gleitpunkt

H = 70 mm

Suitable as fixed or sliding point

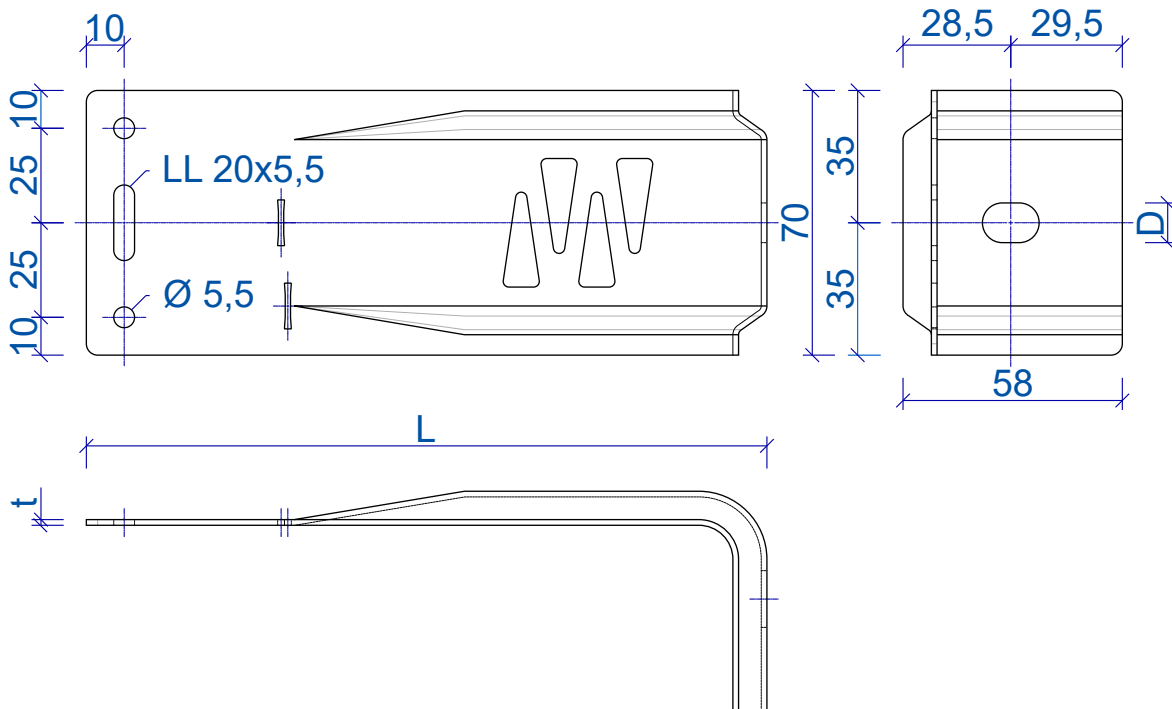

L = 120 / 140 / 160 / 180 / 200 / 220 / 240 / 260 / 280 / 300 / 320 / 340 mm

t = 1,5 mm

D = 10,5x15 mm

Zubehörteile

Accessories

Bohrschraube SDA5/3,5-8-H13-S4-5,5x22
Drilling screw SDA5/3,5-8-H13-S4-5,5x22

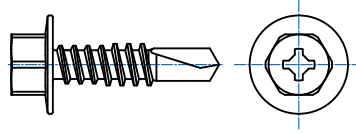

Weitere Verbindungsmittel auf Anfrage
Further connecting device on demand

Haltefeder (Edelstahl)
Inox-spline (Stainless steel)



Einlegescheibe 10,5
Insert washer 10,5



Einlegescheibe 10,5/2x6,6
Insert washer 10,5/2x6,6



Zubehörteile

Accessories

fischer Langschaftdübel SXR 10 x L FUS

fischer frame fixing SXR 10 x L FUS

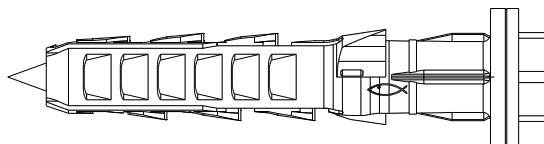

fischer Langschaftdübel SXRL 10 x L FUS

fischer frame fixing SXRL 10 x L FUS

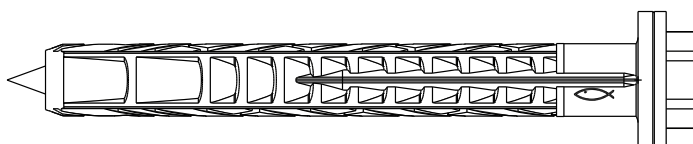

fischer Injektionssysteme FIS V

fischer injection systems FIS V

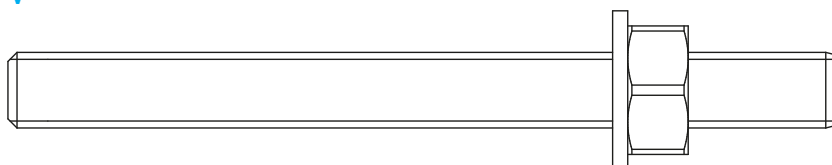

fischer Bolzenanker FAZ II / R

fischer bolt anchors FAZ II / R

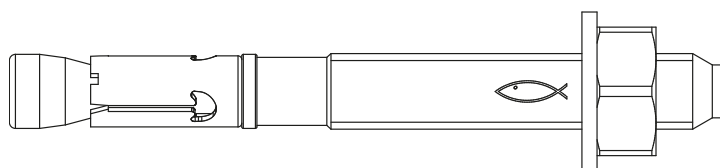

Weitere Verankerungsmittel (auch Verankerung in Stahl/Holz/etc.): auf Anfrage
Further anchoring elements (also anchoring in steel/wood/etc.): on demand